

# MCK200

Permanent Magnet Synchronous Gearless Traction Machine

永磁同步无齿轮曳引机

MONADRIVE®

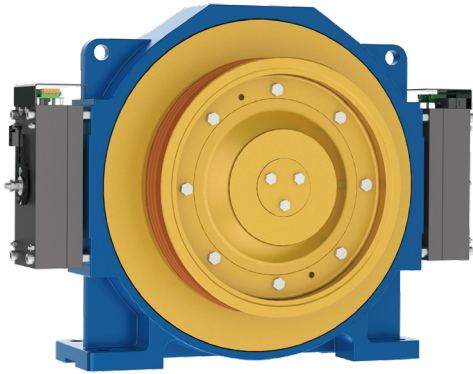

• 电源电压	Voltage	380V	• 曳引比	Roping	1:1 / 2:1
• 额定载重	Elv. Load	(630~1150)kg	• 额定梯速	Elv.Speed	(1.0~2.5)m/s
• 曳引轮节径	Sheave Diam	400mm / 450mm	• 工作制	Duty	S5-40%
• 最大轴静载	Max.Static Load	4000kg	• 绝缘等级	Ins.Class	F
• 制动器	Brake	DC110V 2x1.3A	• 自重	Weight	315kg

## 安装尺寸图 DIMENSIONS

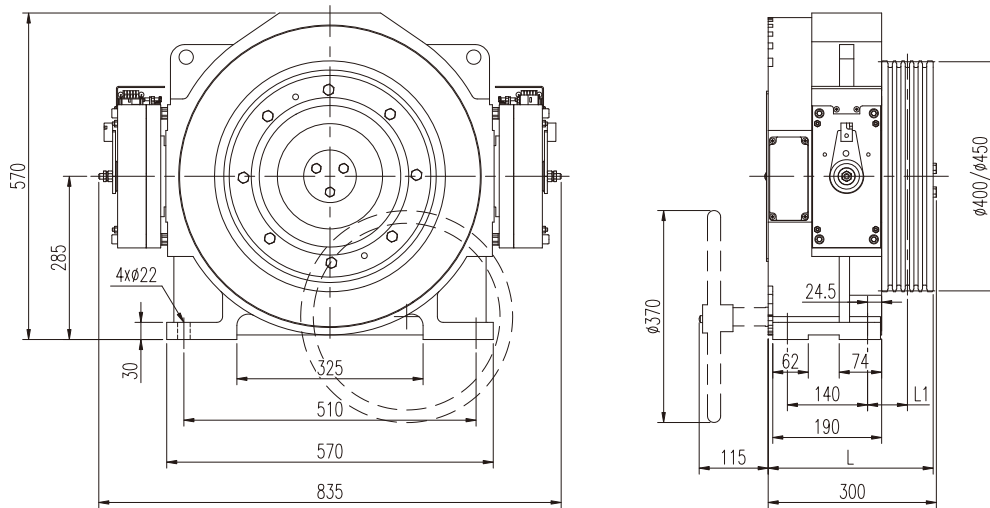

## 规格表 SPEC.SHEET

型号	Type	MCK200												
规格	额定载重	额定梯速	曳引轮节径	曳引轮绳槽	额定电流	额定功率	额定转速	额定频率	额定转矩	极数	L	L1	切口角	
Spec.	Load	Elv. Speed	Sheave Diam.	Sheave Groove	Current	Power	Speed	Freq.	Torque	Poles	mm	mm	β Angle	
	kg	m/s	mm		A	kW	r/min	Hz	N·m				°	
<b>Roping 曳引比 2:1</b>														
630-1.0	630	1.0	400	4×Φ10×15	10	4.3	95	25.3	430	32	288	69.5	95	
630-1.5	630	1.5	400	4×Φ10×15	14	6.4	143	38.1	430	32	288	69.5		
630-1.6	630	1.6	400	4×Φ10×15	16	6.9	153	40.8	430	32	288	69.5		
630-1.75	630	1.75	400	4×Φ10×15	16	7.5	167	44.5	430	32	288	69.5		
630-2.0A	630	2.0	400	4×Φ10×15	18	8.6	191	50.9	430	32	288	69.5		
630-2.0B	630	2.0	450	4×Φ10×15	18	8.5	170	45.3	480	32	288	69.5		
800-1.0	800	1.0	400	5×Φ10×15	12	5.4	95	25.3	540	32	288	69.5		
800-1.5	800	1.5	400	5×Φ10×15	18	8.1	143	38.1	540	32	288	69.5		
800-1.6	800	1.6	400	5×Φ10×15	20	8.7	153	40.8	540	32	288	69.5		
800-1.75	800	1.75	400	5×Φ10×15	20	9.4	167	44.5	540	32	288	69.5		
800-2.0A	800	2.0	400	5×Φ10×15	23	10.8	191	50.9	540	32	288	69.5		
800-2.5A	800	2.5	400	6×Φ10×15	28	13.5	239	63.7	540	32	300	75.5		
800-2.0B	800	2.0	450	5×Φ10×15	23	10.7	170	45.3	600	32	288	69.5		
800-2.5B	800	2.5	450	5×Φ10×15	29	13.3	212	56.5	600	32	288	69.5		
1000-1.0	1000	1.0	400	5×Φ10×15	15	6.7	95	25.3	670	32	288	69.5		
1000-1.5	1000	1.5	400	5×Φ10×15	23	10.0	143	38.1	670	32	288	69.5		
1000-1.6	1000	1.6	400	5×Φ10×15	26	10.7	153	40.8	670	32	288	69.5		
1000-1.75	1000	1.75	400	5×Φ10×15	26	11.7	167	44.5	670	32	288	69.5		
1000-2.0A	1000	2.0	400	5×Φ10×15	28	13.4	191	50.9	670	32	288	69.5		
1000-2.5A	1000	2.5	400	6×Φ10×15	34	16.8	239	63.7	670	32	300	75.5		
1000-2.0B	1000	2.0	450	5×Φ10×15	28	13.4	170	45.3	750	32	288	69.5		
1000-2.5B	1000	2.5	450	6×Φ10×15	36	16.6	212	56.5	750	32	300	75.5		
1150-1.0	1150	1.0	400	5×Φ10×15	17	7.8	95	25.3	780	32	288	69.5		
1150-1.5	1150	1.5	400	6×Φ10×15	25	11.7	143	38.1	780	32	300	75.5		
1150-1.6	1150	1.6	400	6×Φ10×15	29	12.5	153	40.8	780	32	300	75.5		
1150-1.75	1150	1.75	400	6×Φ10×15	29	13.6	167	44.5	780	32	300	75.5		
1150-2.0	1150	2.0	400	6×Φ10×15	33	15.6	191	50.9	780	32	300	75.5		
<b>Roping 曳引比 1:1</b>														
450-1.0	450	1.0	400	5×Φ10×15	10	3.4	48	12.8	670	32	288	69.5	95	
630-1.0	630	1.0	400	6×Φ10×15	11	4.0	48	12.8	670	32	300	75.5		

MONADRIVE®